

Int -7010

Step 1

Remove original visor & Take off original brackets if it has any. Unscrew original brackets from the truck.

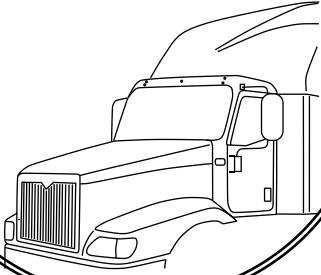

Step 2

Assemble visor with brackets. Mark the side holes of visor. Drill out to a 1/2 diameter & put in weld nuts. If no side holes are present, then drill those out first.

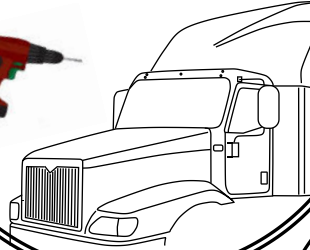

Step 3

Mount new brackets & tighten them on to the truck.

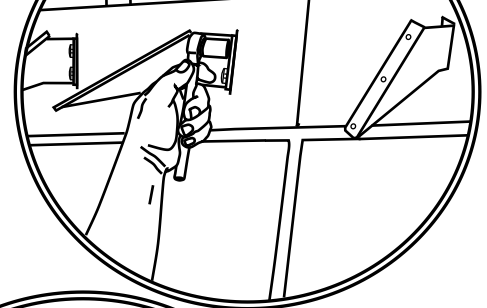

Step 4

Place the visor over brackets & tighten all the screws.

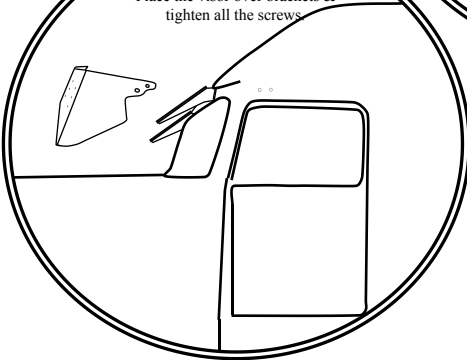

Step 5

You are finished! Remove plastic off the visor & clean with windex.

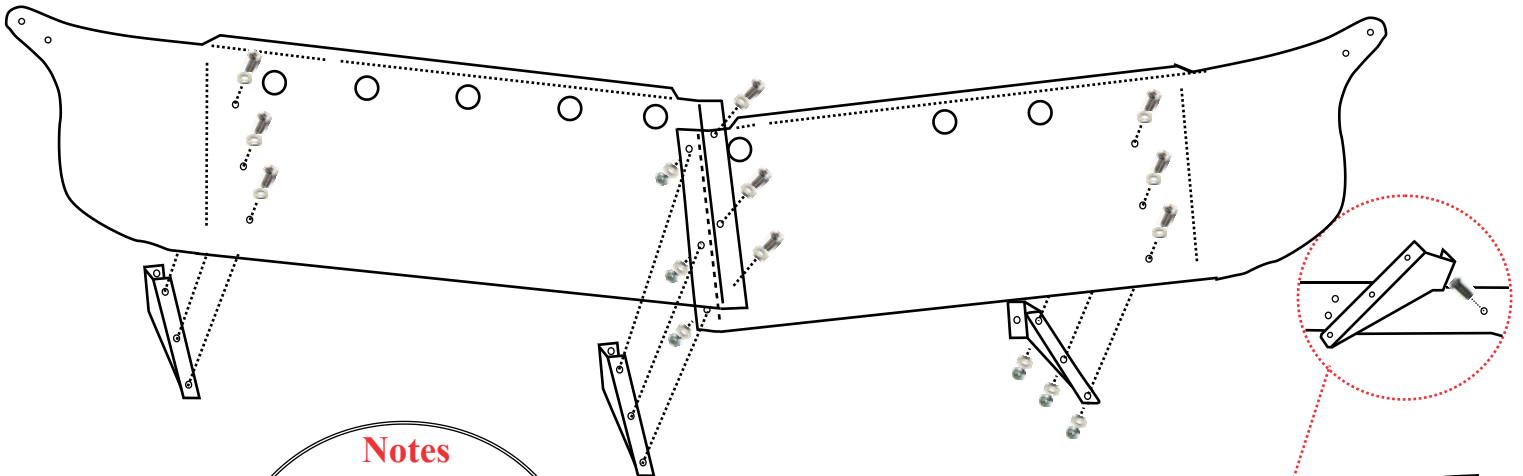
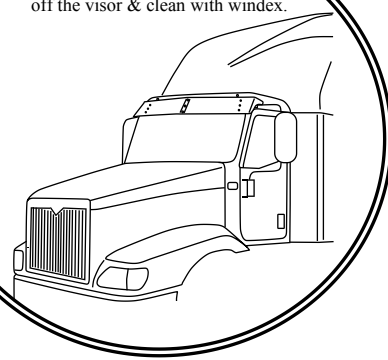

Notes

- Use silicone or something similar to patch any exposed holes once installation is completed.
- Drill cautiously to avoid puncturing the cabs interior.
- Insert screws "loosely" starting from outer edge to center. Then start "tightening" from center to outer edge.

Bolt Kit

	QTY: 9	Pan Phillips	1/4 - 20 x 3/4
	QTY: 24	Flat Washer	1/4 x 5/8
	QTY: 6	Weld Nut	1/4 - 20 x 1"
	QTY: 6	Hex Head	1/4 - 20 x 1 1/4
	QTY: 9	Nylon Hex Nuts	1/4 x 20

